

T-A® Original Drill Inserts

Z Series | Carbide | Diameter Range: 11.10mm - 12.95mm (0.437" - 0.510")

A

DRILLING

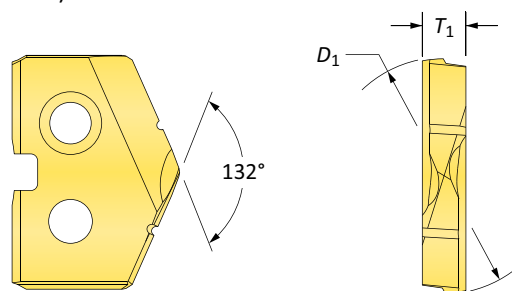

B

BORING

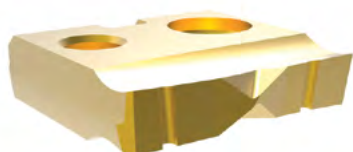

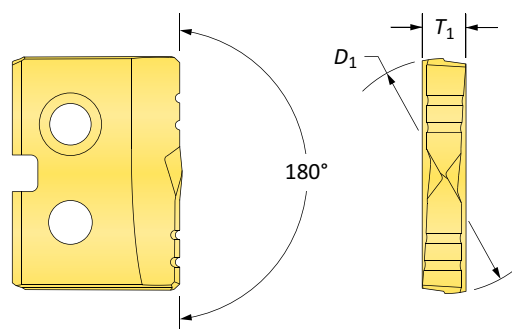

Flat Bottom



C

REAMING

Carbide Inserts – K20 (C2)

Insert				Part No.		Flat Bottom Part No.
D ₁ mm	D ₁ inch	Fractional Equivalent	T ₁ mm			
				TiN	TiAlN	TiN
11.11	0.4375	7/16	2.38	1C2ZT-0014	1C2ZA-0014	1C2ZT-0014-FB
11.46	0.4510	–		1C2ZT-.451	1C2ZA-.451	1C2ZT-.451-FB
11.50	0.4528	–		1C2ZT-11.5	1C2ZA-11.5	1C2ZT-11.5-FB
11.51	0.4531	29/64		1C2ZT-.453	1C2ZA-.453	1C2ZT-.453-FB
11.91	0.4688	15/32		1C2ZT-0015	1C2ZA-0015	1C2ZT-0015-FB
12.00	0.4724	–		1C2ZT-12	1C2ZA-12	1C2ZT-12-FB
12.30	0.4844	31/64		1C2ZT-.484	1C2ZA-.484	1C2ZT-.484-FB
12.50	0.4921	–		1C2ZT-12.5	1C2ZA-12.5	1C2ZT-12.5-FB
12.70	0.5000	1/2		1C2ZT-0016	1C2ZA-0016	1C2ZT-0016-FB
12.85	0.5060	–		1C2ZT-.506	1C2ZA-.506	1C2ZT-.506-FB
12.95	0.5100	–		1C2ZT-.510	1C2ZA-.510	1C2ZT-.510-FB

D

BURNISHING

F

THREADING

X

SPECIALS

Key on A30: 1

A30: 114 - 145

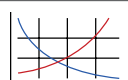

A30: 28 - 31



A30: 4 - 6

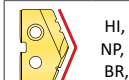

HI, HR, CR, TC, SK,
NP, IN, RN, CN, AN,
BR, CI, CP, NC, WC

A30: 4 - 6

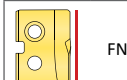

FN

Coatings not listed above can be supplied as non-stocked standards.



TiN = 131T-XXXX	TiAlN = 131A-XXXX
TiCN = 131N-XXXX	AM200® = 131H-XXXX

Inserts sold in quantities of 2