

T-A® Drill Insert Holders

1 Series | Flanged Shank

A

DRILLING

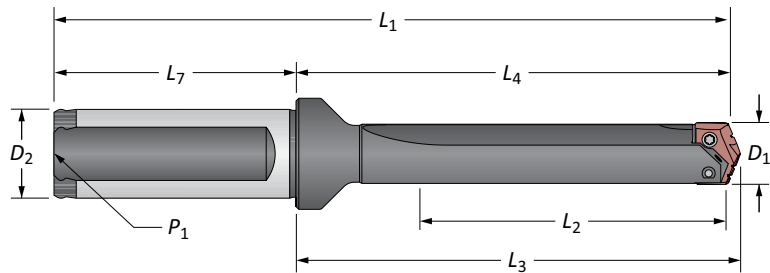

B

BORING



Stub Length

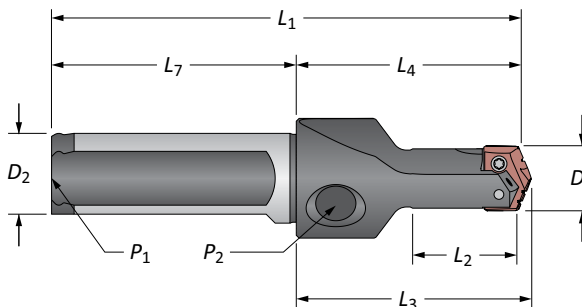

C

REAMING

Straight Flute

Series	Length	D <sub>1</sub>	Body				Shank			Part No.
			L <sub>2</sub>	L <sub>4</sub>	L <sub>3</sub>	L <sub>1</sub>	D <sub>2</sub>	L <sub>7</sub>	P <sub>1</sub>	
1	Stub	18.0 - 24.0	47.6	75.8	79.4	131.8	25.0	56.0	1/8*	21010S-25FM
	Short	18.0 - 24.0	66.7	107.2	110.7	163.2	25.0	56.0	1/8*	22010S-25FM
	XL	18.0 - 24.0	457.0	494.5	498.1	550.5	25.0	56.0	1/8*	▲ 27010S-25FM
	3XL	18.0 - 24.0	569.0	602.5	606.1	658.5	25.0	56.0	1/8*	▲ 29010S-25FM
1.5	Stub	22.0 - 24.0	57.2	88.5	92.1	144.5	25.0	56.0	1/8*	21015S-25FM
	Short	22.0 - 24.0	66.7	107.2	110.7	163.2	25.0	56.0	1/8*	22015S-25FM
1	Stub	45/64 - 15/16	1-7/8	2-63/64	3-1/8	5-17/64	1	2-9/32	1/8	21010S-100F
	Short	45/64 - 15/16	2-5/8	4-7/32	4-23/64	6-1/2	1	2-9/32	1/8	22010S-100F
	Intermediate	45/64 - 15/16	4-5/8	6-3/32	6-15/64	8-3/8	1	2-9/32	1/8	23010S-100F
	Standard	45/64 - 15/16	6-5/8	8-3/32	8-15/64	10-3/8	1	2-9/32	1/8	24010S-100F
	Extended	45/64 - 15/16	10-5/8	12-3/32	12-15/64	14-3/8	1	2-9/32	1/8	▲ 25010S-100F
1.5	Stub	55/64 - 15/16	2-1/4	3-31/64	3-5/8	5-49/64	1	2-9/32	1/8	21015S-100F
	Short	55/64 - 15/16	2-5/8	4-7/32	4-23/64	6-1/2	1	2-9/32	1/8	22015S-100F
	Intermediate	55/64 - 15/16	4-5/8	6-3/32	6-15/64	8-3/8	1	2-9/32	1/8	23015S-100F
	Standard	55/64 - 15/16	6-5/8	8-3/32	8-15/64	10-3/8	1	2-9/32	1/8	24015S-100F
	Extended	55/64 - 15/16	10-5/8	12-3/32	12-15/64	14-3/8	1	2-9/32	1/8	▲ 25015S-100F

\*Metric thread to BSP and ISO 7-1

NOTE: Stub length holders have a 1/8" side pipe tap (P<sub>2</sub>)

D

BURNISHING

Connection Accessories

Series	Insert Screws	Nylon Locking Screws	Insert Driver	Preset Torque Hand Driver	Replacement Tips	Admissible Tightening Torque*
1	7375-IP9-1	7375N-IP9-1	8IP-9	8IP-9TL	8IP-9B	305 N-cm (27.0 in-lbs)
1.5	739-IP9-1	739N-IP9-1	8IP-9	8IP-9TL	8IP-9B	305 N-cm (27.0 in-lbs)

\*Tightening torques are calculated with a friction coefficient of  $\mu = 0.14$  and develop 90% of ultimate yield strength

F

THREADING

X

SPECIALS

A30: 44 - 51

A30: 57 & 113

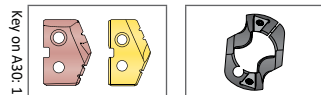

Ⓜ = Metric (mm)

Ⓢ = Imperial (in)

Screws sold in quantities of 10

**WARNING** Refer to Speed and Feed charts for recommended adjustments to speeds and feeds. Refer to page A30: 148 for deep hole drilling guidelines in this section of the catalog. Visit [www.alliedmachine.com](http://www.alliedmachine.com) for the most up-to-date information and procedures. Factory technical assistance is available for your specific applications through our Application Engineering Team.