

Taper shank end mills

lang, coarse teeth



411240

411940

CZ Frézy válcové čelní | s MK, dlouhé, hrubozubé

DE Schaftfräser mit MK | Lang, grobgezahnt

RU Фрезы концевые с коническим хвостовиком | длинные, крупнозубые

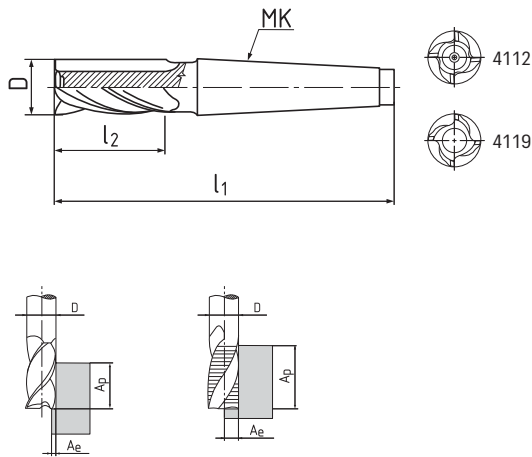

4112

4119



D k 10**	MK	l1		l2		Z		
		4112	4119	4112	4119		411245	411940
25	3	192	184	90	80	4	.250	.250*
32	4	231	229	106	100	4	.320	.320*
40	4	250	250	125	125	4	.400	.400
50	5	308	308	150	150	5	.500	.500
63	5	338	338	180	180	6	.630	.630

*) ≠ DIN 845

**) 411940 = js 14

Cutting conditions | Řežné podmínky | Schnittbedingungen | Условия резания

Material	Ap	Ae	Vc	fz (mm/z)				
				Ø 25	Ø 30	Ø 40	Ø 50	Ø 63
P.1 ≤ 600 N/mm ²	1xD	0,1xD	30	0,071	0,080	0,110	0,012	0,13
P.2 ≤ 850 N/mm ²	1xD	0,1xD	26	0,071	0,080	0,110	0,012	0,13
P.4* ≤ 900 N/mm ²	1xD	0,1xD	24	0,071	0,080	0,110	0,012	0,13
K.1 ≤ 820 N/mm ²	1xD	0,1xD	25	0,071	0,080	0,110	0,012	0,13
N.2 ≤ 600 N/mm ²	1xD	0,1xD	140-240	0,050	0,056	0,077	0,008	0,091
N.4 ≤ 800 N/mm ²	1xD	0,1xD	50-90	0,071	0,080	0,110	0,012	0,13

* Not recommended for 411940 | Není doporučeno pro 411940 | Nicht empfohlen für 411940