

End mills

extra short, NR, N

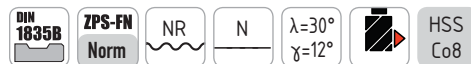

CZ Frézy válcové čelní | extra krátké, NR, N

DE Schaftfräser | Extra kurz, NR, N

RU Фрезы концевые с цилиндрическим хвостовиком | экстремально короткие, NR, N

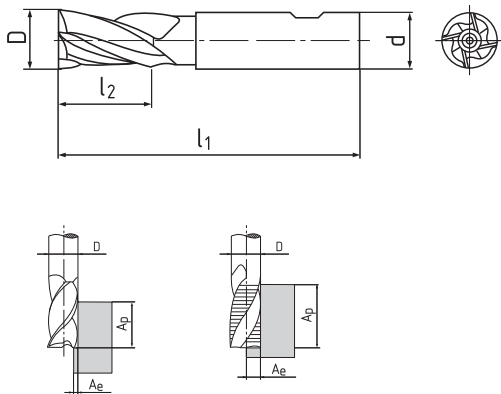

1242K

1202K



D k 12*	d h 6	l1		l2		Z		
		1242K	1202K	1242K	1202K		124218K	120218K
30	20	90	90	30	30	6	.300030	.300030
32	20		90		30	6		.320030
35	20	90	90	30	30	6	.350030	.350030
40	25	95	95	32	32	8	.400032	.400032
50	32	100	100	36	36	8	.500036	.500036

*) 120218K = k 10

Cutting conditions | Řezné podmínky | Schnittbedingungen | Условия резания

Material	Ap	Ae	Vc	fz (mm/z)				
				Ø 30	Ø 35	Ø 40	Ø 50	
124218K								
P.1	≤ 600 N/mm ²	1,5xD	0,5xD	45	0,115	0,13	0,14	0,18
P.2	≤ 850 N/mm ²	1,5xD	0,5xD	39	0,115	0,13	0,14	0,18
P.3	≤ 1100 N/mm ²	1,5xD	0,5xD	24	0,115	0,13	0,14	0,18
P.4	≤ 900 N/mm ²	1,5xD	0,5xD	30	0,115	0,13	0,14	0,18
M.2	750-850 N/mm ²	1,5xD	0,5xD	15	0,115	0,13	0,14	0,18
N.4	≤ 800 N/mm ²	1,5xD	0,5xD	80-120	0,115	0,13	0,14	0,18
120218K								
P.1	≤ 600 N/mm ²	1,5xD	0,5xD	45	0,085	0,098	0,11	0,13
P.2	≤ 850 N/mm ²	1,5xD	0,5xD	39	0,085	0,098	0,11	0,13
P.3	≤ 1100 N/mm ²	1,5xD	0,5xD	24	0,085	0,098	0,11	0,13
P.4	≤ 900 N/mm ²	1,5xD	0,5xD	30	0,085	0,098	0,11	0,13
M.2	750 - 850 N/mm ²	1,5xD	0,5xD	15	0,085	0,098	0,11	0,13
N.4	> 800 N/mm ²	1,5xD	0,5xD	80-120	0,085	0,098	0,11	0,13