

End mills

with corner radius



148517R

120517R

CZ Frézy válcové čelní | s rohovým radiusem

DE Schaftfräser | mit dem Eckenradius

RU Фрезы концевые с цилиндрическим хвостовиком | с радиусом

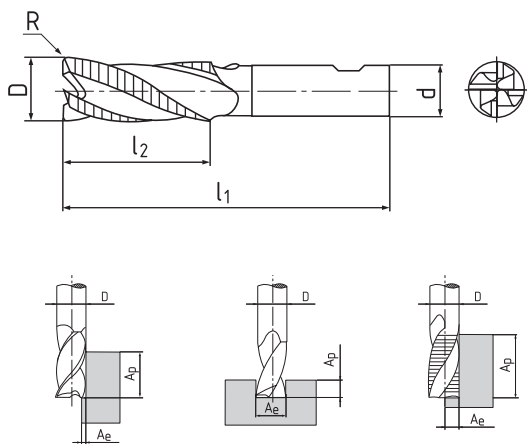

1485R

new



1205R

new



D k 12	d h 6	l1	l2	R	Z		
						148517R	120517R
6	6	57	13	1	4	.060010	.060010
6	6	57	13	2	4	.060020	.060020
10	10	72	22	1	4	.100010	.100010
10	10	72	22	2	4	.100020	.100020
12	12	83	26	1	4	.120010	.120010
12	12	83	26	2	4	.120020	.120020
16	16	92	32	2	4	.160020	.160020
16	16	92	32	4	4	.160040	.160040
20	20	104	38	2	4	.200020	.200020
20	20	104	38	4	4	.200040	.200040

Cutting conditions | Řezné podmínky | Schnittbedingungen | Условия резания

Material	Ap	Ae	Vc	fz (mm/z)						
				Ø 6	Ø 8	Ø 10	Ø 12	Ø 16	Ø 20	
148517R										
P.1	≤ 600 N/mm ²	1,5xD	0,5xD	78	0,035	0,042	0,051	0,06	0,08	0,1
P.3	≤ 1100 N/mm ²	1,5xD	0,5xD	51	0,035	0,042	0,051	0,06	0,08	0,1
P.6	> 1100 N/mm ²	1,5xD	0,5xD	20	0,025	0,029	0,036	0,042	0,056	0,07
M.3	> 850 N/mm ²	1,5xD	0,5xD	37	0,035	0,042	0,051	0,06	0,095	0,13
N.1	≤ 400 N/mm ²	1,5xD	0,5xD	130	0,046	0,055	0,066	0,078	0,104	0,13
N.4	≤ 800 N/mm ²	1,5xD	0,5xD	70	0,035	0,042	0,051	0,06	0,095	0,13
S.1	≤ 1500 N/mm ²	1,5xD	0,5xD	23	0,035	0,042	0,051	0,06	0,095	0,13
S.2	≤ 1250 N/mm ²	1,5xD	0,5xD	23	0,025	0,029	0,036	0,042	0,056	0,07
120517R										
P.1	≤ 600 N/mm ²	1xD	0,1xD	78	0,03	0,036	0,043	0,051	0,068	0,085
P.3	≤ 1100 N/mm ²	1xD	0,1xD	51	0,03	0,036	0,043	0,051	0,068	0,085
P.6	> 1100 N/mm ²	1xD	0,1xD	20	0,021	0,025	0,031	0,036	0,048	0,06
M.3	> 850 N/mm ²	1xD	0,1xD	37	0,03	0,036	0,043	0,051	0,081	0,111
N.1	≤ 400 N/mm ²	1xD	0,1xD	130	0,039	0,047	0,056	0,066	0,088	0,111
N.4	≤ 800 N/mm ²	1xD	0,1xD	70	0,03	0,036	0,043	0,051	0,081	0,111
S.1	≤ 1500 N/mm ²	1xD	0,1xD	23	0,03	0,036	0,043	0,051	0,081	0,111
S.2	≤ 1250 N/mm ²	1xD	0,1xD	23	0,021	0,025	0,031	0,036	0,048	0,06