

SVXCR/L

VNĚJŠÍ SOUSTRUŽENÍ - ISO S VONKAJŠIE SÚSTRUŽENIE - ISO S

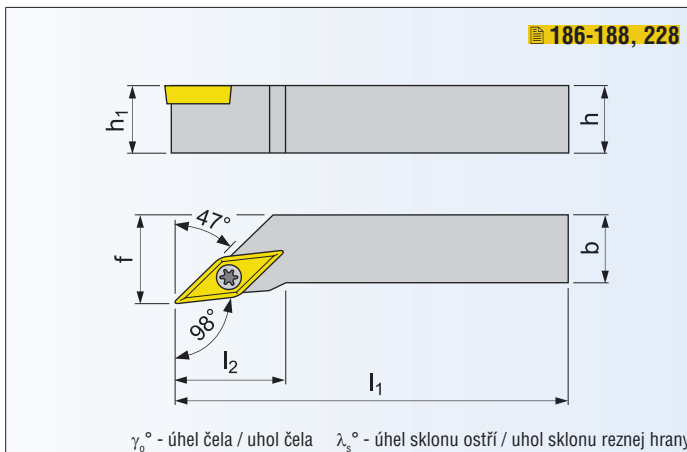
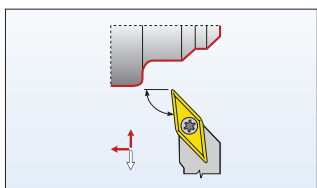
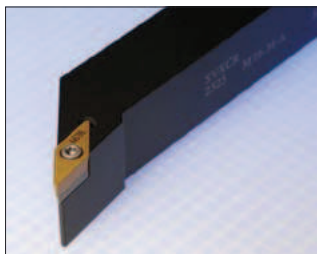

NŮŽ PRO VNĚJŠÍ SOUSTRUŽENÍ / NŮŽ PRE VONKAJŠIE SÚSTRUŽENIE

ISO	R/L	Rozměry / Rozmery [mm]								kg	ND	VBD VRD		
		h=h ₁	b	f	l ₁	l _{2max}			λ_s°				γ_o°	
SVXCR/L 1212 F 11	o/o	12	12	16	80	20				0	0	0,10	SO1	VC.. 1103..
SVXCR/L 1616 H 11	●/●	16	16	20	100	20				0	0	0,20	SO1	VC.. 1103..
SVXCR/L 2020 K 16-M-A	●/●	20	20	25	125	28				0	0	0,75	SV10	VB.. 1604..; VC.. 1604..
SVXCR/L 2525 M 16-M-A	●/●	25	25	32	150	32				0	0	0,68	SV10	VB.. 1604..; VC.. 1604..
SVXCR/L 3225 P 16-M-A	●/o	32	25	32	170	32				0	0	1,10	SV10	VB.. 1604..; VC.. 1604..

NÁHRADNÍ DÍLY / NÁHRADNÉ DIELY

Typ	Up. šroub Up. skrutka	Závít Závít	Podložka Podložka	Mezišroub Medziskrutka	Šroubovák Skrutkovač	Klíč Klúč
SO1	US 2506-T07P	(M2,5x6,3)	-	-	SDR T07P	-
SV10	US 3512-T15P	(M3,5x12,5)	SVN 160304	MS 3510	SDR T15P	HXK 3,5

● skladovaný ○ neskladovaný

všechny rozměry v / všetky rozmery v [mm]

ISO C
ISO C

ISO D
ISO D

ISO M
ISO M

ISO P
ISO P

ISO S
ISO S

ZÁPÍCHY
ZÁPÍCHY

ZÁVITY
ZÁVITY

VBD
VRD