

XCMT-MF

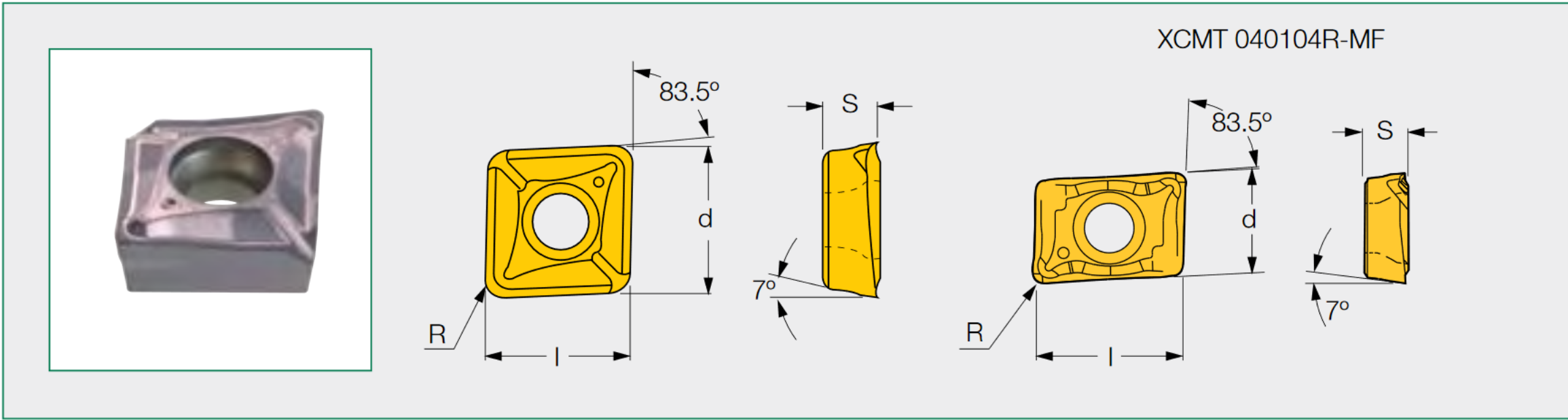

XCMT-MF Inserts for DR-MF Multifunction Tools

Designation	d	l	S	R	IC908
XCMT 040104R-MF⁽¹⁾	4.4	6.4	1.7	0.4	●
XCMT 040104L-MF⁽¹⁾	4.4	6.4	1.7	0.4	●
XCMT 050204-MF	5.6	5.6	2.1	0.4	●
XCMT 060204-MF	6.38	6.38	2.38	0.4	●
XCMT 070304-MF	7.48	7.48	3.18	0.4	●
XCMT 080304-MF	8.44	8.44	3.18	0.4	●
XCMT 10T304-MF	10.5	10.5	3.97	0.4	●
XCMT 10T308-MF	10.5	10.5	3.97	0.8	●
XCMT 130404-MF	13.4	13.4	4.76	0.4	●
XCMT 130408-MF	13.4	13.4	4.76	0.8	●
XCMT 170508-MF	17.4	17.4	5.56	0.8	●

Two cutting edges. For hard materials and interrupted cut.
 Low cutting forces due to high cutting edges and positive angles.

⁽¹⁾ R=Right hand tool
 L=Left hand tool

P	Steel	✓
M	Stainless Steel	✓
K	Cast Iron	✓
S	High Temp. Alloy	
H	Hardened Steel	